



Sorensen

XPD Series

Programmable DC

Power Supply

Operation Manual

XPD 7.5-67
XPD 18-30
XPD 33-16
XPD 60-9
XPD 120-4.5

About AMETEK

AMETEK Programmable Power, Inc., a Division of AMETEK, Inc., is a global leader in the design and manufacture of precision, programmable power supplies for R&D, test and measurement, process control, power bus simulation and power conditioning applications across diverse industrial segments. From bench top supplies to rack-mounted industrial power subsystems, AMETEK Programmable Power is the proud manufacturer of Elgar, Sorensen, California Instruments and Power Ten brand power supplies.

AMETEK, Inc. is a leading global manufacturer of electronic instruments and electromechanical devices with annualized sales of \$2.5 billion. The Company has over 11,000 colleagues working at more than 80 manufacturing facilities and more than 80 sales and service centers in the United States and around the world.

Trademarks

AMETEK is a registered trademark of AMETEK, Inc. Sorensen is a trademark owned by AMETEK, Inc. Other trademarks, registered trademarks, and product names are the property of their respective owners and are used herein for identification purposes only.

Notice of Copyright

XPD Series Programmable DC Power Supply Operation Manual © 2007 AMETEK Programmable Power, Inc. All rights reserved.

Exclusion for Documentation

UNLESS SPECIFICALLY AGREED TO IN WRITING, AMETEK PROGRAMMABLE POWER, INC. ("AMETEK"):

- (a) MAKES NO WARRANTY AS TO THE ACCURACY, SUFFICIENCY OR SUITABILITY OF ANY TECHNICAL OR OTHER INFORMATION PROVIDED IN ITS MANUALS OR OTHER DOCUMENTATION.
- (b) ASSUMES NO RESPONSIBILITY OR LIABILITY FOR LOSSES, DAMAGES, COSTS OR EXPENSES, WHETHER SPECIAL, DIRECT, INDIRECT, CONSEQUENTIAL OR INCIDENTAL, WHICH MIGHT ARISE OUT OF THE USE OF SUCH INFORMATION. THE USE OF ANY SUCH INFORMATION WILL BE ENTIRELY AT THE USER'S RISK, AND
- (c) REMINDS YOU THAT IF THIS MANUAL IS IN ANY LANGUAGE OTHER THAN ENGLISH, ALTHOUGH STEPS HAVE BEEN TAKEN TO MAINTAIN THE ACCURACY OF THE TRANSLATION, THE ACCURACY CANNOT BE GUARANTEED. APPROVED AMETEK CONTENT IS CONTAINED WITH THE ENGLISH LANGUAGE VERSION, WHICH IS POSTED AT WWW.PROGRAMMABLEPOWER.COM.

Date and Revision

February 2009 Revision C

Part Number

TM-PDOP-01XN



Contact Information

Telephone: 800 733 5427 (toll free in North America)
858 450 0085 (direct)
Fax: 858 458 0267
Email: sales@programmablepower.com
service@programmablepower.com
Web: www.programmablepower.com

This page intentionally left blank.

Important Safety Instructions

Before applying power to the system, verify that your product is configured properly for your particular application.

	Hazardous voltages may be present when covers are removed. Qualified personnel must use extreme caution when servicing this equipment. Circuit boards, test points, and output voltages also may be floating above (below) chassis ground.
	The equipment used contains ESD sensitive parts. When installing equipment, follow ESD Safety Procedures. Electrostatic discharges might cause damage to the equipment.

Only *qualified personnel* who deal with attendant hazards in power supplies, are allowed to perform installation and servicing.

Ensure that the AC power line ground is connected properly to the Power Rack input connector or chassis. Similarly, other power ground lines including those to application and maintenance equipment *must* be grounded properly for both personnel and equipment safety.

Always ensure that facility AC input power is de-energized prior to connecting or disconnecting any cable.

In normal operation, the operator does not have access to hazardous voltages within the chassis. However, depending on the user's application configuration, **HIGH VOLTAGES HAZARDOUS TO HUMAN SAFETY** may be normally generated on the output terminals. The customer/user must ensure that the output power lines are labeled properly as to the safety hazards and that any inadvertent contact with hazardous voltages is eliminated.

Guard against risks of electrical shock during open cover checks by not touching any portion of the electrical circuits. Even when power is off, capacitors may retain an electrical charge. Use safety glasses during open cover checks to avoid personal injury by any sudden component failure.

Neither AMETEK Programmable Power Inc., San Diego, California, USA, nor any of the subsidiary sales organizations can accept any responsibility for personnel, material or inconsequential injury, loss or damage that results from improper use of the equipment and accessories.

SAFETY SYMBOLS

 **WARNING**
Risk of Electrical Shock

 **CAUTION**
Refer to Accompanying Documents

 Off (Supply)

 Direct Current (DC)

 Standby (Supply)

 Alternating Current (AC)

 On (Supply)

 Three-Phase Alternating Current

 Protective Conductor Terminal

 Earth (Ground) Terminal

 Fuse

 Chassis Ground

This page intentionally left blank.

Product Family: XPD Series Programmable DC Power Supply

Warranty Period: Five Years

WARRANTY TERMS

AMETEK Programmable Power, Inc. ("AMETEK"), provides this written warranty covering the Product stated above, and if the Buyer discovers and notifies AMETEK in writing of any defect in material or workmanship within the applicable warranty period stated above, then AMETEK may, at its option: repair or replace the Product; or issue a credit note for the defective Product; or provide the Buyer with replacement parts for the Product.

The Buyer will, at its expense, return the defective Product or parts thereof to AMETEK in accordance with the return procedure specified below. AMETEK will, at its expense, deliver the repaired or replaced Product or parts to the Buyer. Any warranty of AMETEK will not apply if the Buyer is in default under the Purchase Order Agreement or where the Product or any part thereof:

- is damaged by misuse, accident, negligence or failure to maintain the same as specified or required by AMETEK;
- is damaged by modifications, alterations or attachments thereto which are not authorized by AMETEK;
- is installed or operated contrary to the instructions of AMETEK;
- is opened, modified or disassembled in any way without AMETEK's consent; or
- is used in combination with items, articles or materials not authorized by AMETEK.

The Buyer may not assert any claim that the Products are not in conformity with any warranty until the Buyer has made all payments to AMETEK provided for in the Purchase Order Agreement.

PRODUCT RETURN PROCEDURE

1. Request a Return Material Authorization (RMA) number from the repair facility (**must be done in the country in which it was purchased**):
 - **In the USA**, contact the AMETEK Repair Department prior to the return of the product to AMETEK for repair:
Telephone: 800-733-5427, ext. 2295 or ext. 2463 (toll free North America)
858-450-0085, ext. 2295 or ext. 2463 (direct)
 - **Outside the United States**, contact the nearest Authorized Service Center (ASC). A full listing can be found either through your local distributor or our website, www.programmablepower.com, by clicking Support and going to the Service Centers tab.
2. When requesting an RMA, have the following information ready:
 - Model number
 - Serial number
 - Description of the problem

NOTE: Unauthorized returns will not be accepted and will be returned at the shipper's expense.

NOTE: A returned product found upon inspection by AMETEK, to be in specification is subject to an evaluation fee and applicable freight charges.

This page intentionally left blank.

About This Manual

This Operating Manual contains operating information for the XPD Series of high-performance, switching, laboratory power supplies, available in several voltage models at 500 watts. It provides information on features and specifications, installation procedures, and basic functions testing, as well as operating procedures for using both front panel control and remote analog programming functions.

Who Should Use This Manual

This manual is designed for the user who is familiar with basic electrical theory, especially as they apply to the operation of power supplies. This implies a recognition of Constant Voltage and Constant Current operating modes and the control of input and output power, as well as the observance of safe techniques while making supply or pin connections and any changes in switch settings.

Main Sections

Section 1 Features and Specifications Describes the power supply and lists its features and specifications.

Section 2 Installation Goes through basic setup procedures. Describes inspection, cleaning, shipping, and storage procedures. Includes AC input connection, basic functions testing, and load and sense lines connections.

Section 3 Local Operation Provides procedures for local (front panel) operation. Includes procedures for using over voltage protection, shutdown function, multiple supplies, and over temperature protection.

Section 4 Remote Operation Covers remote analog programming operation and remote monitoring of output voltage and current.

About This Manual

-

Contents

	About This Manual	vii
Section 1. Features and Specifications	Description	11
	Features and Options	11
	Front Panel Controls	12
	Rear Panel Connectors	13
	Output Connectors	14
	Rear Panel J210 Connector	15
	Making J210 Connections	17
	Wiring	17
	Electrical Specifications	18
	Additional Specifications	19
	Input Conditions	19
	Additional Characteristics	20
	Remote Programming and Monitoring	20
	Environmental Specifications	21
Mechanical Specifications	21	
Section 2. Installation	Introduction	23
	Basic Setup Procedure	23
	Inspection, Cleaning, and Packaging	24
	Initial Inspection	24
	Periodic Cleaning	24
	Returning Power Supplies to the Manufacturer	25
	Return Material Authorization Policy	25
	Packaging for Shipping or Storage	26
	Location, Mounting, and Ventilation	27
	Rack Mounting	27
	Ventilation	27
	AC Input Power Connection	28
	AC Input Connector	28
	AC Input Cord	28
	Functional Tests	29
	Power-on Check	29
	Voltage Mode Operation Check	29
	Current Mode Operation Check	29
	Load Connection	30
Load Wiring	30	
Making Load Connections	31	
Inductive Loads	32	
Connecting Multiple Loads	32	
Remote Sensing	33	
Sense Wiring	34	

Section 3.	Introduction	35
Local Operation	Standard Operation	35
	Operating Modes and Automatic Crossover	35
	Constant Voltage Mode Operation	36
	Constant Current Mode Operation	36
	Setting the Current Limit	36
	Setting the Supply to Operate in CI Mode.	37
	Automatic Mode Crossover.	37
	Shipped Configuration (Local Control Mode).	37
	Using Over Voltage Protection (OVP)	38
	Defining the OVP Setpoint	38
	OVP Circuit Check	38
	Using the Shutdown Function	39
	Controlling Shutdown Function via J210 Connector	39
	Master-Slave Tracking.	39
	Using Multiple Supplies	40
	User Diagnostics	45
	Emergency Shutdown	45
	Unusual or Erratic Operation.	45
	Trouble Shooting for Operators.	45
Section 4.	Introduction	49
Remote Operation	Remote Digital Programming	49
	Remote Analog Programming of Output Voltage and Current Limit	49
	Remote Programming Options	50
	Programming Output Voltage with a 0-10 Vdc Voltage Source	50
	Programming Output Current with a 0-10 Vdc Voltage Source.	50
	Readback and Status Indicators	50
	Voltage and Current Readback.	50
	Status Flags.	51

Section 1. Features and Specifications

Description

The **XPD** Series of DC power supplies provides stable, variable output voltage and current for a broad range of development and system requirements. The units use high-frequency soft-switching technology to achieve high power density and retain a small package size. They feature a built-in analog programming interface, with optional RS-232 and IEEE-488 controlled programming, making this series the first choice in flexible power system design. See [Table 1.1](#) for the list of available models.

Table 1.1 500 Watt Series Models

Model	Output Voltage	Output Current
7.5-67	0-7.5 V	0-67 A
18-30	0-18 V	0-30 A
33-16	0-33 V	0-16 A
60-9	0-60 V	0-9 A
120-4.5	0-120 V	0-4.5 A

Features and Options

- The power supply delivers simultaneous digital displays for both voltage and current, and bar graph displays for monitoring transient changes, which gives the user the benefit of continuous, up-to-date information.
- Active Power Factor Correction (PFC) delivers lower input current and input current harmonics.
- Ten-turn voltage and current controls permits high resolution setting of the output.
- The automatic crossover system allows the power supply to automatically switch operating modes between current or voltage mode.
- Multiple units can be connected in parallel or series to produce greater diversity or for use in high precision applications.
- Short-circuit-proof power outlets give greater operating safety.
- A built-in Analog Programming (APG) Interface provides analog signal control of voltage and current, overvoltage protection (OVP), master/slave output tracking, and remote ENABLE/DISABLE for safety and precision.

Section 1. Features and Specifications

Front Panel Controls

- This unit may be equipped with an optional internal GPIB or RS-232 control for remote digital programming and readback.
- Remote output sensing provides load cable compensation up to 5 V/line (3 V/line for 7.5 V model).
- A rack mount kit (Option RM) is also available for this product.

Front Panel Controls

See [Figure 1.1](#) to review the displays, LEDs, indicators, and controls located on the power supply's front panel. Check the following sections for additional descriptions for front panel controls and functions.

- [“Mechanical Specifications”](#) on page 21
- [“Functional Tests”](#) on page 29
- [“Standard Operation”](#) on page 351

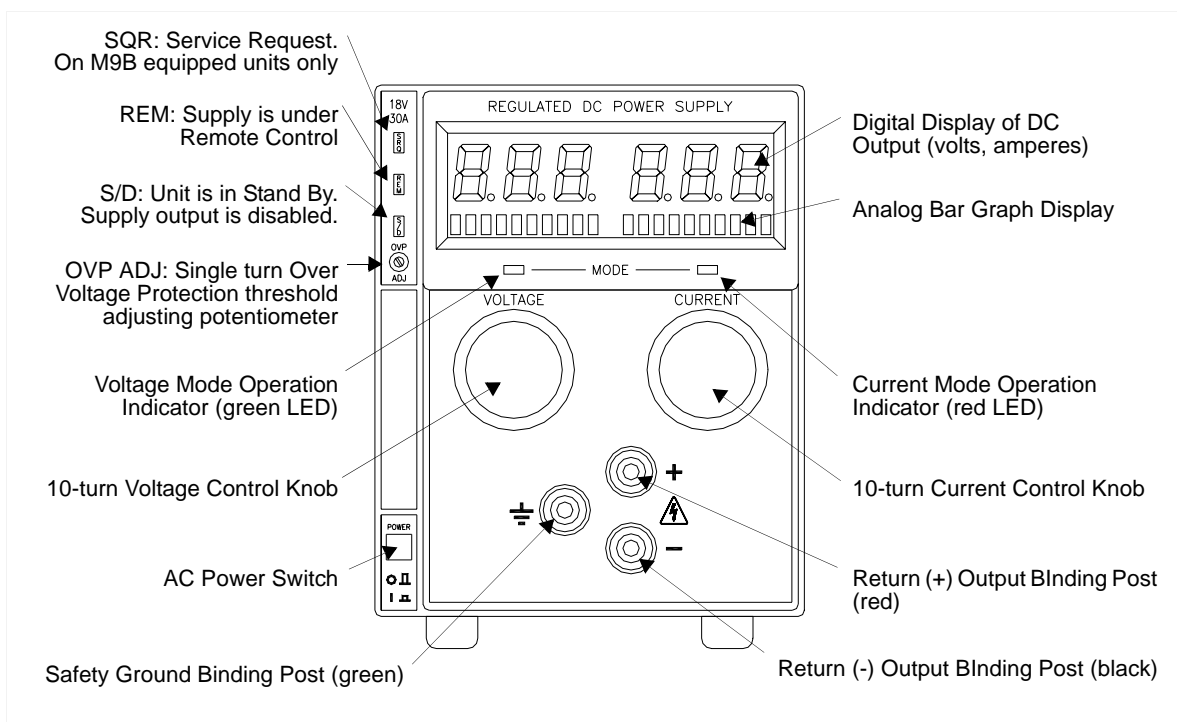

Figure 1.1 500 Watt Series Power Supply Front Panel

Rear Panel Connectors

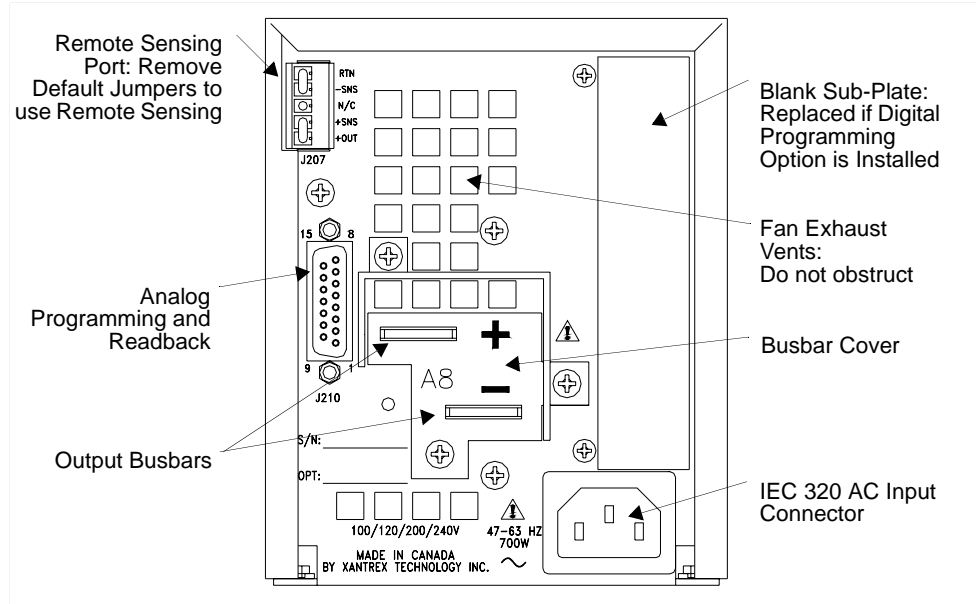

Figure 1.2 500 Watt Power Supply Rear Panel (7.5 V and 18 V)

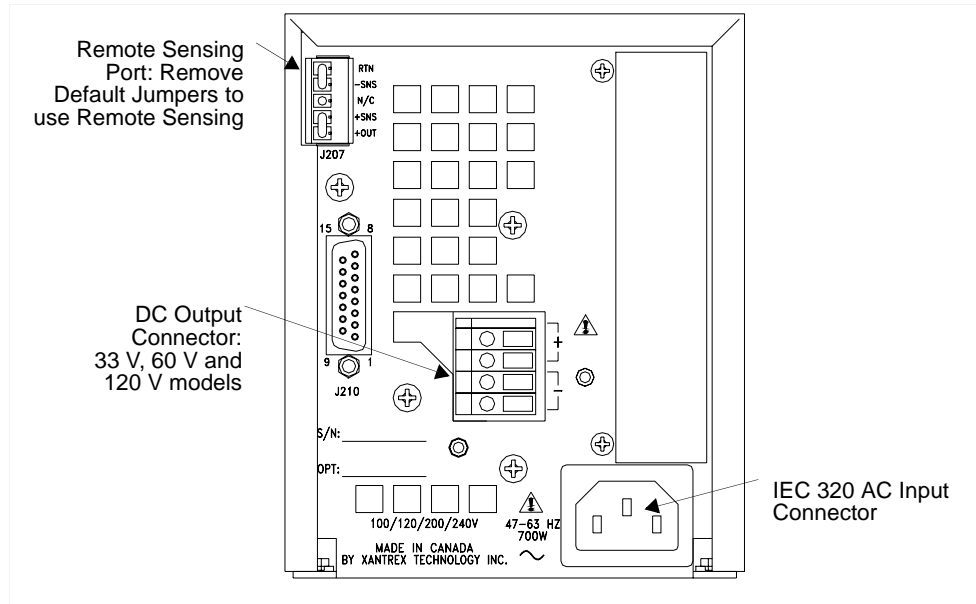

Figure 1.3 500 Watt Power Supply Rear Panel (33 V to 120 V)

Section 1. Features and Specifications

Rear Panel Connectors

Output Connectors **Low Voltage Models** Equipped with positive and negative busbars. The busbars are offset to facilitate load cable connections.



WARNING

Disconnect the AC input before making any connections to the unit.

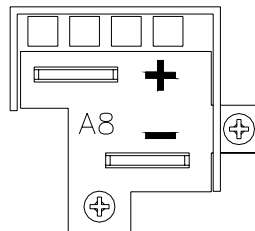

Figure 1.4 Output Busbars - note polarity markings
(Low Voltage Models)

High Voltage Models High voltage models are equipped with a 4-terminal output block. The top two are positive terminals whereas the lower two are negative. Screw clamps are used to secure load connections.



WARNING

Disconnect the AC input before making any connections. Lethal voltages may be present at the output terminals for up to 15 seconds after the AC power has been removed.

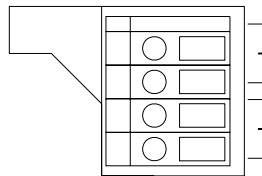

Figure 1.5 Output Terminal - note polarity markings
(High Voltage Models)

Section 1. Features and Specifications

Rear Panel Connectors

Rear Panel J210 Connector The J210 Analog Interface connector is a 15-pin female DSUB connector located on the rear panel. See [Figure 1.6](#). Use the J210 programming, monitoring, and shutdown 15 pin DSUB connector for remote programming and monitoring functions. See [Figure 1.2](#) for the location of the J210 connector at the rear panel. We recommend that you mate the J210 connector with a 15-pin male connector, such as a Tyco 747908-2 or equivalent.

The J210 connector provides access to the following functions:

- Remote programming of both output voltage and current
- Calibrated readback signals for remote monitoring of output voltage and output current
- Isolated remote shutdown function using a 5-15 V signal

See [Figure 1.6](#) for a graphic presentation of the J210 connector and its pinouts.

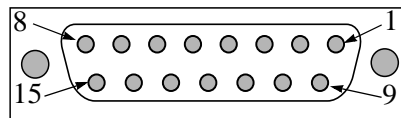

Figure 1.6 Analog Interface Programming and Monitoring J210 Connector

See [Table 1.2](#) for a list of the J210 connector pin numbers, their references, and corresponding functions.

Section 1. Features and Specifications

Rear Panel Connectors

Table 1.2 Rear Panel J210 Connector Pins and Functions

Pin	Reference	Name	Function
J210-1	TTL S/D RTN	Shutdown Signal Return (-)	Return for shutdown signal ¹ .
J210-2	TTL S/D	Shutdown Input (+)	Input for shutdown signal. ¹
J210-3	N/C	No connection	None.
J210-4	N/C	No connection	None.
J210-5	IPGM	Output Current Limit Programming Input	Input for current limit programming signals from an analog device.
J210-6	VRMT SELECT	Remote Output Voltage Programming Select	Selects remote output voltage programming when jumpered to pin 8. ²
J210-7	IRMT SELECT	Remote Output Current Limit Programming Select	Selects remote output current limit programming when jumpered to pin 8. ²
J210-8	AGND	Auxiliary Ground	Auxiliary ground.
J210-9	N/C	No connection	None.
J210-10	N/C	No connection	None.
J210-11	N/C	No connection	None.
J210-12	IMON	Output current monitor	Output for output current monitor signal.
J210-13	PGM/MON RTN	Program/Monitor Return	Return for voltage and current program and monitor signals.
J210-14	VPGM	Output Voltage Programming Input	Input for voltage programming signals from an analog device.
J210-15	VMON	Output Voltage Monitor	Output for output voltage monitor signal.

1. The TTL shutdown circuit is isolated to 500 V from the power supply output and chassis.
2. Jumpering pins J210-6, J210-7, and J210-8 will select both remote output voltage programming and remote output current limit programming.

Making J210 Connections



CAUTION

Program/monitor signal and return are internally connected to the power supply negative output. Do not attempt to bias these away from that potential.



CAUTION

To maintain the isolation of the power supply output and prevent ground loops, use an isolated (ungrounded) programming source when operating the power supply via remote analog control at the J210 connector.



CAUTION

Before making connections from external circuits to the J210 connector, turn the power supply OFF and wait until the front panel displays have gone out.

Wiring



WARNING

There is a potential shock hazard at the output when using a power supply with a rated output greater than 40 V. Use load wiring with a minimum insulation rating equivalent to the maximum output voltage of the power supply. For example, select TEW, 105 °C, 300 V wiring for use with a 120 V, 4.5 A power supply.

For most connectors and jumpers, use any suitable wire such as 16 to 24 AWG stranded wire. For lowest noise performance, use shielded pair wiring of 16 to 24 AWG. Use the shortest leads possible. Ground the shield to pin 8 (auxiliary ground) on the J210 connector or to the chassis via one of the J210 connector screws.

Section 1. Features and Specifications

Electrical Specifications

Electrical Specifications

These specifications are warranted over a temperature range of 0 °C to 50 °C with local sense. Above 50 °C, derate output linearly to zero at 70 °C. Nominal line voltages are 100/120/200/230/240 Vac. Specifications and characteristics refer to a single output model unless otherwise stated, and specifications apply to either front or rear outputs unless noted.

Table 1.3 Electrical Specifications for 7.5 V to 120 V Models

Models	7.5-67	18-30	33-16	60-9	120-4.5
Output Ratings:					
Output Voltage	0-7.5 V	0-18 V	0-33 V	0-60 V	0-120 V
Output Current	0-67 A ¹	0-30 A	0-16 A	0-9 A	0-4.5 A
Output Power	502.5 W	540 W	528 W	540 W	540 W
Line regulation: ²					
Voltage (0.01% of Vmax + 2 mV)	2.8 mV	3.8 mV	5.3 mV	8 mV	14 mV
Current (0.01% of Imax + 1 mA)	7.7 mV	4 mV	2.6 mV	1.9 mV	1.5 mV
Load Regulation: ³					
Voltage (0.01% of Vmax + 2 mV)	2.8 mV	3.8 mV	5.3 mV	8 mV	14 mV
Current (0.01% of Imax + 5 mA)	11.7 mA	8 mA	6.6 mA	5.9 mA	5.5 mA
Meter Accuracy					
Voltage (1% of Vmax + 1 count)	0.2 V	0.3 V	0.5 V	0.7 V	2.2 V
Current (1% of Imax + 1 count)	0.8 A	0.4 A	0.3 A	0.2 A	0.2 A
Output Noise (0-20 MHz):					
Voltage (p-p)	50 mV	50 mV	75 mV	125 mV	180 mV
Output Ripple (0-100 kHz) (rms):					
Voltage	5 mV	5 mV	7.5 mV	10 mV	20 mV
Current ⁴	250 mA	250 mA	150 mA	150 mA	75 mA
Drift (60 minutes): ⁵					
Voltage (0.15% of Vmax)	11.3 mV	27 mV	49.5 mV	90 mV	180 mV
Current (0.3% of Imax)	201 mA	90 mA	48 mA	27 mA	13.5 mA
Drift (8 hours): ⁶					
Voltage (0.03% of Vmax)	2.3 mV	5.4 mV	9.9 mV	18 mV	36 mV
Current (0.05% of Imax)	34 mA	15 mA	8 mA	4.5 mA	2.3 mA
Temperature Coefficient: ⁷					
Voltage (0.015% of Vmax/ ^o C)	1.2 mV	2.7 mV	5 mV	9 mV	18 mV
Current (0.02% of Imax/ ^o C)	13.4 mA	6 mA	3.2 mA	1.8 mA	0.9 mA
OVP Adjustment Range:					
Minimum (5% of Vmax)	0.4 V	0.9 V	1.7 V	3 V	6 V
Maximum (110% of Vmax)	8.3 V	19.8 V	36.3 V	66 V	132 V
Efficiency ⁸					
	81%	83%	85%	85%	84%

Section 1. Features and Specifications

Additional Specifications

1. Front output current limited to 30 A maximum.
2. For input voltage variation over the AC input voltage range, with constant rated load.
3. For 0 to 100% load variation, with constant nominal line voltage (rear output only).
4. Current mode noise is measured from 10% to 100% of rated output voltage, full current, resistive load.
5. Maximum drift over 60 minutes with constant line, load, and temperature, after power on.
6. Maximum drift over 8 hours with constant line, load, and temperature, after 60-minute warm-up.
7. Change in output per ° C change in ambient temperature, with constant line and load.
8. Typical efficiency is measured at 120 V and full output power.

Additional Specifications

Rise Time (No load, full load)	50 ms
Fall Time (Full load)	50 ms
Fall Time (No load)	400 ms
Voltage Mode Transient Response	1 ms
Time delay from power on until output stable	3 s maximum

Input Conditions

Rated AC Input Voltage	100/120/200/230/240 Vac, universal input
Maximum AC Input Power	700 W
Operational AC Input Voltage Range	85 to 264 Vac; power factor corrected
Maximum Input Current	7 A maximum at 100 Vac, 6 A maximum at 120 Vac, 3 A maximum at 220 Vac
Input Frequency Range	47 to 63 Hz
Power Factor	0.98 minimum for full load at nominal voltage
Input Harmonic Distortion	Current harmonics meet IEC 1000-3-2

Section 1. Features and Specifications

Additional Characteristics

Additional Characteristics

Over Temperature Protection (OTP)	Unit latches off when T > rated maximum. Auto restart when cool
OVP Control	Adjustable on front panel single turn control. 110% setting 5% of rated output
Switching Frequency	125 kHz (250 kHz output ripple)
Output Hold-up Time	10 ms @120 Vac input
Insulation Resistance	Input to chassis: >30 M ohm, with 500 Vdc Output to chassis: >20 M ohm, with 1000 Vdc
Isolation Voltage	Input to output: 1350 Vac

Remote Programming and Monitoring

Remote S/D and Interlock ¹	5–15 V signal or TTL-compatible output, selectable logic. TTL input impedance: 2 k (in series with one diode drop)
Remote Analog Programming (Full Scale Input)	Voltage and current programming inputs (source must be floating): 0-10 V voltage sources. Input impedance (V and I): 20 k
Remote Monitoring	Output voltage and current: 0-10 V Output impedance (V and I): approximately 221 ohm; output short circuit current: approximately 20 mA (load must be floating)
Remote Programming and Monitoring Accuracy	1% of full scale output for the default range
Maximum Remote Sense Line Drop Compensation	7.5 V model: 3 V/line; ² 18-120 V models: 5 V/line ²
Optional Digital Control	RS-232, GPIB interfaces

1. Isolated from power supply output and chassis to 500 V.
2. Line drop must be deduced from supply maximum output.

Environmental Specifications

Operating Temperature Range	0 to 50 °C
Storage Temperature Range	-40 to 85 °C
Humidity Range	Up to 95% RH non-condensing
Operating Altitude	Maximum 6,500 feet (2,000 m) Derate maximum operating temperature by 1 °C per 1,000 feet (300 m) for operation between 5,000 feet (1500 m) and 6,500 feet (2,000 m)
Storage Altitude	Up to 50,000 feet (15 000 m)
Installation Category	II
Pollution Degree	2

Mechanical Specifications

Front Panel Voltage and Current Control	10-turn voltage and current potentiometers
Front Panel Voltage Control Resolution	0.02% of maximum voltage
Front Panel Current Control Resolution	0.02% of maximum current
Front Panel Voltage and Current Meters	3-digit green numeric LED displays. For meter accuracy, see Table 1.3, on page 18
AC Input Connector Type	IEC 320 connector, appropriate power cord provided for destination country
Input Fuses	Non-user accessible, both lines fused.
Output Connector	Front panel: 5-way binding posts maximum current limit 30 A Rear panel: 7.5–18 V models: bus bars with 0.3" holes. 33–120 V models: wire clamp connectors
Sense Connector	5 terminal wire clamp connector
Analog Programming Connector	15-pin female DSUB connector
Chassis Ground	Front panel binding post; chassis is grounded through power cord
Cooling	Fan cooled. Variable speed fan. Air flows from front to rear, with vents on top, bottom, and sides

Section 1. Features and Specifications

Mechanical Specifications

Mounting	Optional 19 in. (483 mm) rack mount kit (mounts 4 units).
Maximum Dimensions (single output)	Free standing: Height: 5.55 in. (140 mm) Width: 4.24 in (108 mm) Mounted: Height: 5.25 in.(133 mm) (3 U). Width: 1/4 rack (4 per 19 in. rack) Depth: 13 in. (330 mm) (not including front panel controls and front and back output terminals)
Weight	Single output: 9.0lb. (4.1 kg)
Approvals	CSA certified to UL 3101-1, CSA C22.2 No. 1010-1, and 1010-1B FCC Part 15B and Industry Canada Class A CE Marked for Low Voltage Directive and EMC Directive (Class A emissions)
Accessories	Rack mount kit
Options	GPIB, RS-232 interfaces

Section 2. Installation

Introduction

This section provides recommendations and procedures for inspecting, installing, and testing the power supply.

Basic Setup Procedure

See [Table 2.1](#) for a summary of the basic setup procedure and a view of the subsections in this section. Use this procedure as a quick reference if you are unfamiliar with the installation requirements for the power supply. Each step in the procedure refers to subsequent sections which contain more details. Follow each step in the sequence given.

Table 2.1 Basic Setup Procedure

Step #	Description	Action	Reference
1	Inspection	Perform an initial physical inspection of the power supply.	“Inspection, Cleaning, and Packaging” on page 24
2	Installation	Install the supply (bench or rack mount). Ensure adequate ventilation.	“Location, Mounting, and Ventilation” on page 27
3	Input Power	Connect AC input power.	“AC Input Power Connection” on page 28
4	Test	Perform functional tests for voltage mode operation, current mode operation, and front panel controls.	“Functional Tests” on page 29
5	Load	Connect the load.	“Load Connection” on page 30
6	Sensing	Connect sensing lines.	“Remote Sensing” on page 33

Section 2. Installation

Inspection, Cleaning, and Packaging

Inspection, Cleaning, and Packaging

- Initial Inspection** When you first receive your unit, perform a quick physical check.
1. Inspect the unit for scratches and cracks in the chassis and front panel, and for broken switches, connectors, and displays.
 2. If you see external damage or suspect internal damage, have a service technician check the unit before attempting to use it. If the unit is damaged, save all packing materials and notify the carrier immediately. See packing instructions in [“Returning Power Supplies to the Manufacturer” on page 25](#).
 3. Ensure that the packing box contains the 7.5' (2.5 m) power cord.
- Periodic Cleaning** No routine servicing of the power supply is required, except for periodic cleaning. Whenever a unit is removed from operation, clean the metal surfaces with naphtha or an equivalent solvent and the front panel with a weak solution of soap and water. Use low-pressure compressed air to blow dust from components on the printed circuit boards.

Returning Power Supplies to the Manufacturer

Return Material Authorization Policy Before returning a product directly to Xantrex you must obtain a Return Material Authorization (RMA) number and the correct factory “Ship To” address. Products must also be shipped prepaid. Product shipments will be refused and returned at your expense if they are unauthorized, returned without an RMA number clearly marked on the outside of the shipping box, if they are shipped collect, or if they are shipped to the wrong location.

When you contact Xantrex to obtain service, please have your operating manual ready for reference and be prepared to supply:

- The serial number of your product
- Information about the installation and use of the unit
- Information about the failure and/or reason for the return
- A copy of your dated proof of purchase

When you ship:

1. Package the unit safely following the procedures on [page 26](#), preferably using the original box and packing materials. Please ensure that your product is shipped fully insured in the original packaging or equivalent. This warranty will not apply where the product is damaged due to improper packaging.
2. Include the following:
 - The RMA number supplied by Xantrex Technology Inc clearly marked on the outside of the box.
 - A return address where the unit can be shipped. Post office boxes are not acceptable.
 - A contact telephone number where you can be reached during work hours
 - A brief description of the problem

Ship the unit prepaid to the address provided by your Xantrex customer service representative.

If you are returning a product from outside of the USA or Canada:

In addition to the above, you **MUST** include return freight funds and are fully responsible for all documents, duties, tariffs, and deposits.

If you are returning a product to a Xantrex Authorized Service Center (ASC):

A Xantrex return material authorization (RMA) number is not required. However, you must contact the ASC prior to returning the product or presenting the unit to verify any return procedures that may apply to that particular facility.

Section 2. Installation

Returning Power Supplies to the Manufacturer

Packaging for Shipping or Storage

Follow these instructions to prepare the unit for shipping or storage.

1. When returning the unit or sending it to the service center, attach a tag to the unit stating its model number (available from the front panel label) and its serial number (available from the rear panel label). Give the date of purchase and an invoice number, if you have it, as well as a brief description of the problem.
2. For storage or shipping, repack the power supply in its original container. If the original container is not available, seal the unit in a plastic bag and then pack it in a 200 lb. (90 kg) test, corrugated cardboard carton large enough to allow 2 inches (5 cm) of cushioning material to surround the unit. Use a material such as foam slabs or chips.
3. Label the carton as shown in [Figure 2.1](#).
4. If shipping, mark the address of the service center and your return address on the carton.
5. If storing, stack no more than eight cartons high. Check the storage temperature range and storage altitude specification in [“Environmental Specifications” on page 21](#).

POWER SUPPLY
Model Number: _____
Serial Number: _____
FRAGILE — ELECTRONIC EQUIPMENT

Figure 2.1 Shipping or Storage Carton Label

Location, Mounting, and Ventilation

You may use the 500 watt power supply in rack-mounted or in benchtop applications.

Rack Mounting



WARNING

Ensure that any mounting screws do not penetrate more than 1/8 in. (3.0 mm) into the bottom and/or back of the unit

The power supply is designed to fill 1/4 of a standard 19 in. (483 mm) equipment rack.

Units can be combined with 300 watt and 60 watt series models for customer applications. Contact the manufacturer about the RM (Rack Mount Kit) option.

Ventilation

Whether operating the power supply in a rack or on a bench, allow cooling air to reach the ventilation inlets on the bottom and sides of the unit. Ensure that rack-mounted units have 1 U (1.75 in./44.5 mm) between units. Ventilation space at the top and bottom, or sides of the power supply is essential for proper operation.

See [“Environmental Specifications” on page 21](#), for the operating ambient temperature range and the operating altitude specification.

Section 2. Installation
AC Input Power Connection

AC Input Power Connection



WARNING

There is a potential shock hazard if the power supply chassis and cover are not connected to an electrical ground via the safety ground in the AC input connector. Ensure that the power supply is connected to a grounded AC outlet with the recommended AC input cord configured for the available line voltage as described in this section.



WARNING

Disconnect AC power from the unit before removing the cover. Even with the front panel power switch in the OFF position, live line voltages are exposed when the cover is removed. Repairs must be made only by experienced service technicians.



CAUTION

When the power switch is turned on, the output voltage or current previously set will be applied to loads

AC Input Connector

The AC input connector is a standard IEC 15 A, 250 V male connector located on the power supply's rear panel. See [Figure 1.2 500 Watt Power Supply Rear Panel \(7.5 V and 18 V\)](#), p. 13.

AC Input Cord



WARNING

The AC input cord is the disconnect device for the power supply. The plug must be readily identifiable by and accessible to the operator. The input cord must be no longer than 9.85 feet (3 m).

The AC input cord that we provide is appropriate to the country of destination. If you require a special cord, contact us.

Functional Tests

These functional test procedures include power-on and front panel function checks as well as voltage and current mode operation checks.

- Power-on Check**
1. Ensure that the front panel power switch is in the extended (OFF) position and the voltage and current controls are in their fully counter-clockwise positions.
 2. Ensure that the AC line voltage is within operating range.
 3. Plug the line cord into a grounded AC outlet.
 4. Push the power switch to turn on the power supply.

After a short power-on delay, the display and the red current mode LED lights. The meter reading remains at zero.

For more about standard operations, see [“Standard Operation” on page 35.](#)

- Voltage Mode Operation Check**
1. Ensure that the front panel voltage and current control are turned fully counter-clockwise.
 2. Set the power switch to ON.
 3. Rotate the current control one half-turn clockwise. Slowly rotate the voltage control clockwise and observe the digital meter. Minimum control range should be from zero to maximum rated output. Observe the bar graph meter to see that it tracks as the voltage rises. Verify that the voltage mode indicator light is ON.
 4. Set the power switch to OFF.

- Current Mode Operation Check**
1. Ensure that the front panel power switch is set to OFF.
 2. Rotate the voltage and current controls fully counter-clockwise.
 3. Rotate the voltage control one half-turn clockwise.
 4. Connect a short circuit across the output terminals. Use leads of sufficient current carrying capacity.
 5. Set the power switch to ON.
 6. Rotate the current control slowly clockwise. The control range should be from zero to the maximum rated output¹. Also check that the current bar graph meter follows the rise in current and that the current mode indicator light is ON.
 7. Set the power switch to OFF.

-
1. On 7.5-67 model, front panel current is limited to 30 A. Short the rear busbar terminals to test the full current range is required.

Section 2. Installation
Load Connection

Load Connection

This section provides recommendations for load wires and covers single and multiple load configurations.

Load Wiring Make load connections at the rear of the power supply at the positive (+) and negative (-) terminals.

To select wiring for connecting the load to the power supply, consider the following factors:

- insulation rating of the wire
- current carrying capacity of the wire
- maximum load wiring length for operation with sense lines
- noise and impedance effects of the load lines

Insulation Rating Use load wiring with a minimum insulation rating equivalent to the maximum output voltage of the power supply.

Current Carrying Capacity As a minimum, load wiring must have a current carrying capacity greater than the output rating of the power supply. This ensures that the wiring will not be damaged, even if the load is shorted. [Table 2.2](#) shows the maximum current rating, based on 450 A/cm², for various gauges of wire rated for 105 °C operation. Operating at the maximum current rating results in an approximately 30 °C temperature rise for a wire operating in free air. Where load wiring must operate in areas with elevated ambient temperatures or bundled with other wiring, use larger gauges or wiring rated for higher temperatures.

Table 2.2 Current Carrying Capacity for Load Wiring

Wire Size (AWG)	Maximum Current (A)	Wire Size (AWG)	Maximum Current (A)
20	2.5	6	61
18	4	4	97
16	6	2	155
14	10	1	192
12	16	1/0	247
10	21	2/0	303
8	36		

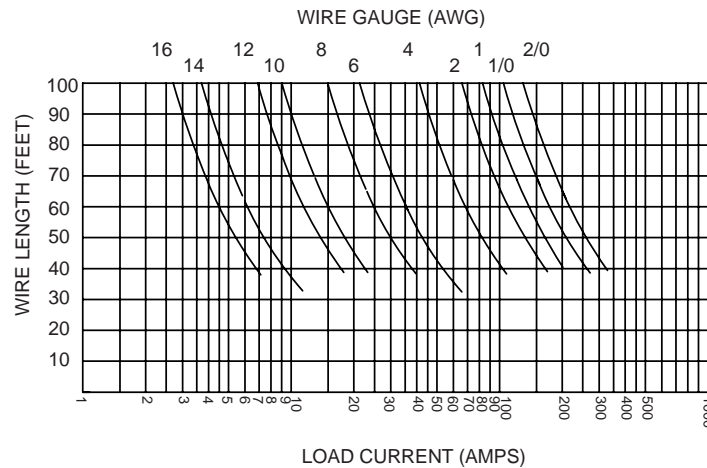

Figure 2.2 Maximum Load Wire Length for 1 V Line Drop

Noise and Impedance Effects To minimize noise pickup or radiation, use shielded pair wiring of shortest possible length for load wires. Connect the shield to the power supply chassis. Where shielding is impossible or impractical, simply twisting the wires together will offer some noise immunity.

Making Load Connections



WARNING

There is a shock hazard at the load when using a power supply with a rated output greater than 40 V. To protect personnel against accidental contact with hazardous voltages, ensure that the load, including connections, has no live parts which are accessible. Also ensure that the insulation rating of the load wiring and circuitry is greater than or equal to the maximum output voltage of the power supply.



CAUTION

When making connections to the bus bars, ensure that each terminals' mounting hardware and wiring assembly are placed to avoid touching the other terminal and shorting the power supply output. Heavy connecting cables must have some form of strain relief to avoid loosening the connections or bending the bus bars.

Section 2. Installation

Load Connection

Inductive Loads To prevent damage to the power supply from inductive kickback, connect a diode across the output. The diode must be rated at least 20% greater than the supply's output voltage and have a current rating greater than or equal to the supply's output rating. Connect the cathode to the positive output and the anode to the return.

Where positive load transients such as back EMF from a motor may occur, connect a transorb or a varistor across the output to protect the power supply. The breakdown voltage rating for the transorb or varistor must be approximately 10% higher than the rated supply output.

Connecting Multiple Loads Proper connection of distributed loads is an important aspect of power supply use. Two common methods of connection are the parallel power distribution method and the radial power distribution method.

Radial Power Distribution Method To connect distributed loads, we recommend that you use this method. With this method, you connect power to each load individually from a single pair of terminals designated as the positive and negative distribution terminals. This pair of terminals may be the power supply output terminals, the load terminals, or a distinct set of terminals specially established for distribution. In this scheme, there are no ground loops and the effect of one load upon another is minimized.

Connect the remote sense leads to these terminals to compensate for losses and minimize the effect of one load upon another. See [“Remote Sensing”](#) below for more information about using remote sensing.

Parallel Power Distribution Method This distribution method involves connecting leads from the power supply to one load, from that load to the next load, and so on for each load in the system. The voltage at each load depends on the current drawn by the other loads and DC ground loops are developed. Except for low-current applications, we recommend that you do not use this method.

Remote Sensing

Remote sensing permits you to shift the regulation point of the power supply from the output terminals to the load or other distribution terminals. It compensates for voltage losses of up to a total of 5 V in the power leads supplying the load (3 V on 7.5 V unit).

For best noise performance, use shielded pair wiring of 16 to 24 AWG for remote sense lines.

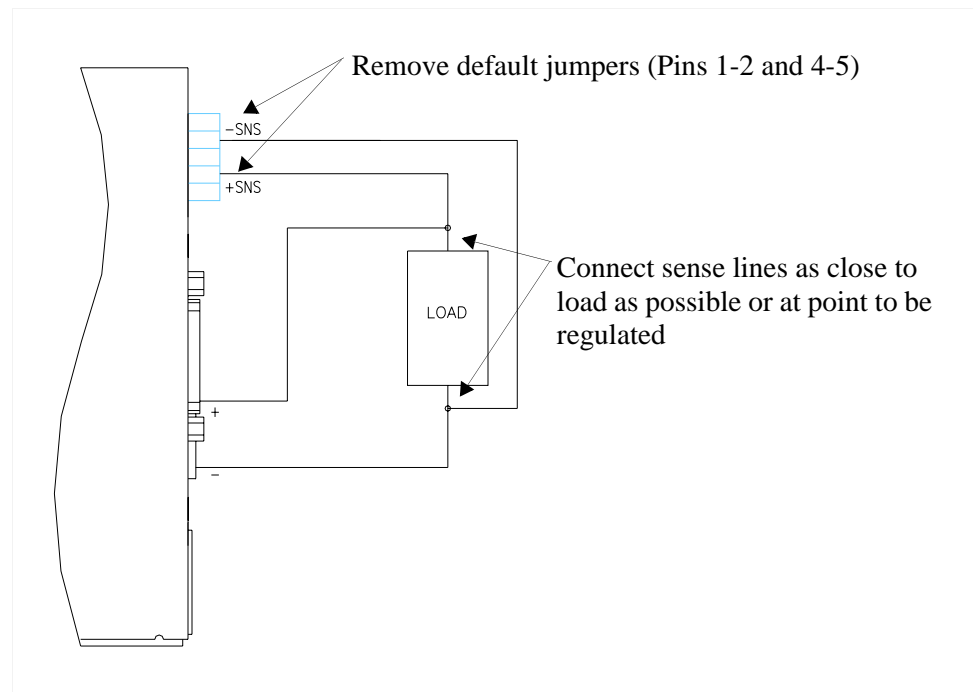

In order to connect the sense wires, follow this procedure:

1. Using a small flat blade screwdriver, remove the two sense jumpers on the J207 connector.
2. Using the appropriate gauge shielded wire (see [“Sense Wiring”](#)), connect one end to the load or point at which load is to be regulated.
3. Connect the positive sense line from the load to J207-4 (+SNS) and the return or (-SNS).

Section 2. Installation

Remote Sensing

To compensate for losses in power leads connected to the output, your power supply provides sense connections beside the output terminals. With remote sense leads in place, the supply regulates to the displayed voltage at the point where the sense lines are connected to the output leads (provided the sum of these lead losses does not exceed 5 V per line or 3.5 V per line for a 7.5 V unit). With the sense lines disconnected, the supply regulates the voltage at the output terminals.

Do not operate the supply with sense lines connected to the load without also connecting the load power leads to the output terminals. Avoid reversing positive and negative lead connections.

Note Long load leads with large capacitance at the load and remote sensing can cause voltage instability due to inductance of the load leads. Measures to reduce inductance and/or capacitance (raising resonant frequency) or using local sense can be beneficial in stabilizing the system.

Sense Wiring



WARNING

There is a potential shock hazard at the sense connectors when using a power supply with a rated output greater than 40 V. Select wiring with a minimum insulation rating equivalent to the maximum output voltage of the power supply for use as local sense jumpers or for remote sense wires. Ensure that connections at the load end are shielded to prevent contact with hazardous voltages.

Section 3. Local Operation

Introduction

Once you have installed the power supply, it is ready to operate in local control mode (that is, operation at the unit's front panel).

- See “Standard Operation” for a brief explanation of Constant Voltage and Constant Current Mode operation.
- See “Using Over Voltage Protection (OVP)” on page 38, “Using the Shutdown Function” on page 39, and “Using Multiple Supplies” on page 40 for information on these topics.
- See “User Diagnostics” on page 45, for troubleshooting information for the operator.
- Turn to Section 4. Remote Operation for descriptions of remote programming options and remote monitoring of the supply.

Standard Operation

This power supply has two basic operating modes: Constant Voltage Mode and Current Mode, and two control modes: Local Control Mode (default setting) and Remote Programming Mode. Both operating modes are available regardless of which control mode is used.

Operating Modes and Automatic Crossover

The mode in which the power supply operates at any given time depends on the combination of:

- output voltage setting V_{SET}
- output current limit setting I_{SET}
- resistance of the attached load R_L

See Figure 3.1 for a graphical representation of the relationships between these variables.

Section 3. Local Operation

Standard Operation

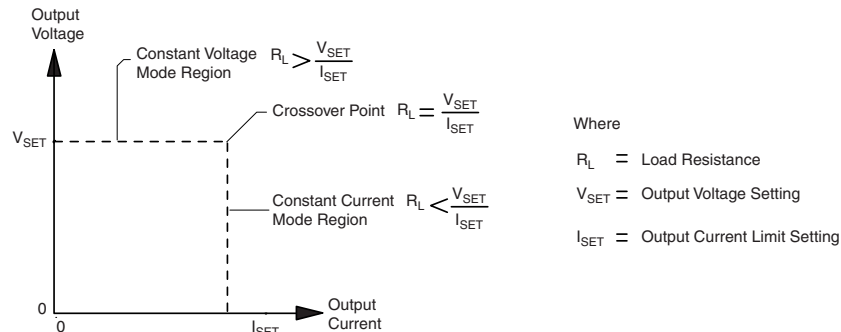

Figure 3.1 Operating Modes

Note The control circuits have been designed to allow you to set output voltage and current up to 1.5% over the model-rated maximum values. The power supply will operate within these extended ranges, but we cannot guarantee full performance to specification.

Constant Voltage Mode Operation

The power supply will operate in constant voltage mode whenever the load current I_L is less than the current limit setting I_{SET} , or: $I_L < I_{SET}$ (Note: $I_L = V_{SET} / R_L$). In constant voltage mode, the power supply maintains the output voltage at the selected value (V_{SET}) while the load current I_L varies with the load requirements.

To use the power supply in Constant Voltage mode, either set the current limit to maximum by turning the current control to its extreme clockwise position, or take the precaution of setting a desired maximum current, then set the voltage control to the desired voltage.

Constant Current Mode Operation

The power supply will operate in Constant Current mode whenever the load resistance is low enough that the load current I_L is greater than the current limit setting I_{SET} , or: $I_L > I_{SET}$. In constant current mode, the power supply maintains the output current at the selected value (I_{SET}) while the load voltage varies with the load requirements.

Setting the Current Limit

Set the Current Limit by following the steps below:

1. Connect a shorting lead across the output terminals.
2. Turn the voltage control a half-turn clockwise.
3. Set the desired maximum current limit by turning the current control slowly clockwise to the desired level.

Section 3. Local Operation
Shipped Configuration (Local Control Mode)

4. Disconnect the shorting lead from the output terminals. The power supply will now automatically switch into current limiting mode (current regulation) as soon as the preset current level is reached.

Setting the Supply to Operate in CI Mode

To operate the supply in CI mode:

1. Set the current limit as described above.
2. Set the voltage control fully clockwise or to the compliance voltage of the circuit.

As soon as the supply starts operating in current mode, the red current mode LED will turn on.

Automatic Mode Crossover

The automatic crossover system allows the power supply to automatically switch operating modes in response to changing load requirements. For example, if the load current attempts to increase above the setting of the current adjust control, the unit will switch automatically from Constant Voltage to Constant Current mode. If you lower the load requirements, the supply will automatically return to Constant Voltage mode.

Shipped Configuration (Local Control Mode)

The factory ships units already configured for local control (front panel) operation. See Table for a summary of this configuration.

Table 3.1 Shipped Configuration (Local Control Mode)

Local Control Configuration	Additional References
Use the front panel controls to adjust output voltage and current limit settings.	See Section for front panel operation. See Section 4, page 49, for remote analog programming procedures.
The OVP set point is adjusted at the front panel to over 110% of rated output voltage.	See “Using Over Voltage Protection (OVP)” on page 38, for the adjustment procedure.

Section 3. Local Operation

Using Over Voltage Protection (OVP)

Using Over Voltage Protection (OVP)

The OVP circuit protects the load in the event of a remote programming error, an incorrect voltage control adjustment, or a power supply failure. The protection circuit monitors the output voltage at the output of the power supply and will shut down the main power converter whenever a preset voltage limit is exceeded. Set the preset voltage limit (also called the setpoint or trip level) using the screwdriver-adjustable front panel OVP ADJ potentiometer, or via one of the optional GPIB or RS-232 programming interfaces.

Defining the OVP Setpoint

1. Turn the power supply OFF.
2. Using a small, flat-blade screwdriver, turn the OVP ADJ potentiometer screw to a fully clockwise position.
3. Turn the power supply ON. Set the output to the desired trip voltage.
4. Slowly turn the OVP ADJ potentiometer screw counter-clockwise until the red OVP indicator lamp lights.
5. Push the power switch to OFF.
6. Turn the voltage control knob to minimum.
7. Push the power switch ON and increase the voltage to check that the power supply shuts off the output at the set voltage.
8. Reset the OVP circuit after activation by removing the overvoltage condition and turning the unit OFF and back ON, or, by momentarily activating the TTL remote shutdown circuit. See “Using the Shutdown Function” on page 39, for information about shutdown circuit operation.

OVP Circuit Check

1. Turn power supply ON.
2. Adjust voltage to maximum. Adjust the front panel OVP ADJUST potentiometer counter-clockwise.
3. The OVP LED will light up and the output of the power supply will drop to near zero.
4. Rotate the front panel OVP ADJUST potentiometer fully clockwise.
5. Momentarily apply 5-15 V across J210 pins 1-2 (P1 -ve, P2 +ve) or cycle the AC input power.
6. The power supply output will recover, indicating that the OVP circuit was reset by momentarily activating the TTL S/D logic or cycling the AC power.

Using the Shutdown Function

Use the shutdown function to disable or enable the supply's output via a logic level signal so that you can make adjustments to either the load or the power supply without shutting off the power supply. Activate this function via remote control through the rear panel J210 Programming and Monitoring connector, using a transistor-transistor logic (TTL) or CMOS compatible signal. The input lines of the shutdown circuit are optically isolated and will withstand a highpot test potential of 500 Vac maximum to chassis.

Controlling Shutdown Function via J210 Connector The shutdown circuit accepts a TTL or CMOS-compatible signal to disable or enable the power supply output. Make connections for signals at the rear panel J210 connector. See "Rear Panel J210 Connector" on page 15, for more information about the J210 connector.

To activate the shutdown function:

- Connect the control signal source between J210 connector pin 2 (shutdown/positive) and pin 1 (shutdown return/negative).

Master-Slave Tracking

Note It is important to note that a Master-Slave configuration only applies to 2 positive outputs, not split supply operation.

For tracking positive and negative outputs, use the following setup:

1. Connect master return (J210 connector pin 13) to slave RTN (J210 connector pin 13).
2. Connect master Vmon (J210 connector pin 15) to slave voltage program input (J210 connector pin 14).

Note Master/slave power supplies must have the same output ratings. As the slave is referenced to the master's output, the noise and ripple on the slave may increase. In addition, if the master's output decreases due to the current limit acting, the output voltage of the slave will follow. However, overcurrent of the slave supply and consequent output voltage decrease will not reflect on the master.

Section 3. Local Operation

Using Multiple Supplies

Using Multiple Supplies

**WARNING**

There is a shock hazard at the load when using a power supply with a rated *or combined* output greater than 40 V. To protect personnel against accidental contact with hazardous voltages created by series connection, ensure that the load, including connections, has no live parts which are accessible. Also ensure that the insulation rating of the load wiring and circuitry is greater than or equal to the maximum *or combined* output voltage of the power supply.

**CAUTION**

Do not connect power supplies from different manufacturers in parallel or in series.

**CAUTION**

The remote programming inputs are internally referenced to the supply's negative output. Do not connect remote programming ground lines (J210 terminal 8,13) to the supply's positive output.

You can operate power supplies of the **SAME MODEL** with outputs in series or in parallel to obtain increased load voltage or increased current. Split supply operation gives you two positive outputs, or a positive and a negative output.

Configuring Multiple Supplies for Series Operation (Voltage Mode Only)

Connect power supplies in series to obtain a single output supply with higher output voltage. Connect the negative (-) terminal of one supply to the positive (+) terminal of the next supply. The total voltage available is the sum of the maximum voltages of each supply (add voltmeter readings). The maximum current available to the load is equal to the current of the lowest rated supply in the series. See Figure 3.2 for a representation of series operation.

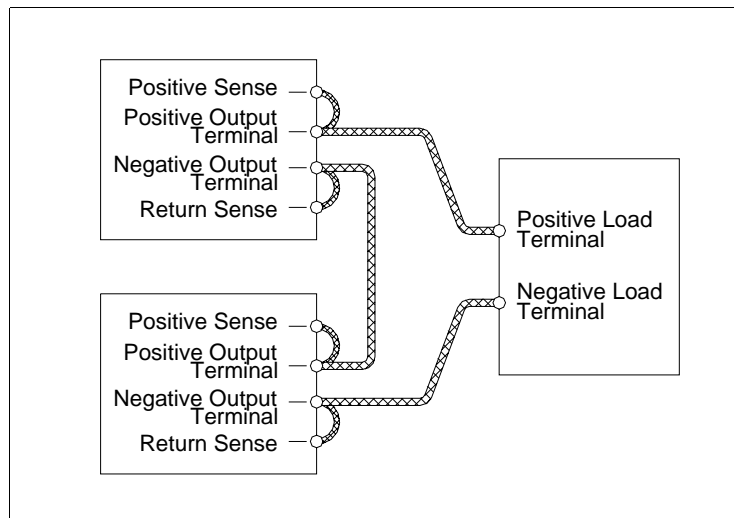

Figure 3.2 Series Operation

Note You do not need to use remote sensing for series operation. If you choose to use it, refer to “Remote Sensing” on page 33.

Section 3. Local Operation

Using Multiple Supplies

Configuring Multiple Supplies for Parallel Operation

CAUTION For parallel operation, set all OVP trip points higher than the maximum output voltage.

Connect power supplies in parallel to obtain a single output supply with a higher output current limit. Set all of the outputs to the same voltage before connecting the positive (+) and negative (-) terminals in parallel. The total current available is the sum of the maximum currents of each supply.

The maximum voltage available at the load is equal to the voltage of the lowest rated supply. When you connect two supplies in parallel, the supply with the higher voltage setting will be in the current limiting mode, while the other supply controls the output voltage.

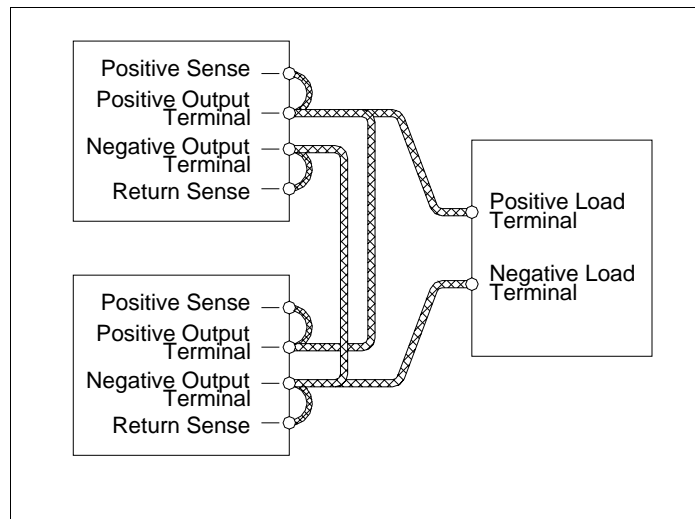

Figure 3.3 Parallel Operation

Configuring Multiple Supplies for Split Supply Operation

Split supply operating uses two power supplies to obtain two positive voltages with a common ground, or to obtain a positive-negative supply.

Two Positive Voltages To obtain two positive voltages, connect the negative output terminals of both supplies together in a common connection. The positive output terminals will provide the required voltages with respect to the common connection.

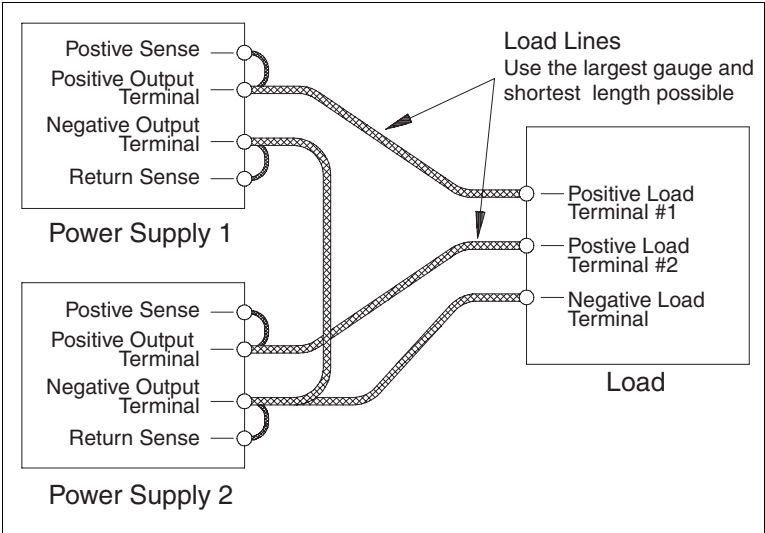

Figure 3.4 Split Supply Operation of Multiple Supplies (Two positive voltages)

Section 3. Local Operation

Using Multiple Supplies

Positive-negative supply To obtain a positive-negative supply, connect the negative output terminal of one supply to the positive terminal of the second supply. The positive output terminal of the first supply now provides a positive voltage relative to the common connection. The negative output terminal of the second supply provides the negative voltage. The current limits can be set independently of each other. The maximum current available in split operation is equal to the rated output of the supplies.

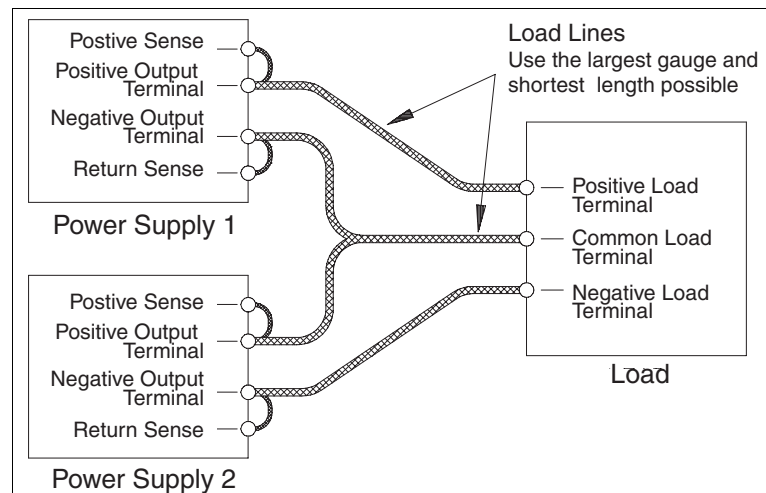

Figure 3.5 Split Supply Operation of Multiple Supplies (Positive-negative Supply)

Note Split supply operation requires the use of an isolated analog interface card on the slave unit. In this arrangement, one-knob control of both supplies is possible

User Diagnostics

If your power supply is not performing as described in this manual, run through the procedures and checks in this section before calling your service technician. These procedures are confined to operator level functions only. They do not require cover-off servicing.

- Emergency Shutdown** In an emergency, carry out both of these steps:
1. Shut the power supply OFF immediately.
 2. Disconnect the mains supply, if possible.
 3. Disconnect the power supply from the load.

- Unusual or Erratic Operation** If the power supply displays any unusual or erratic operation, follow these steps:
1. Shut the power supply OFF immediately.
 2. Disconnect the power supply from the load and external programming.
 3. Test the power supply with no load, running the tests in “Functional Tests” on page 29.
 4. If the tests show that the power supply is functioning normally, check all load, programming, and monitoring connections and circuits.
 5. Check the AC input for correct voltage and frequency.

If the problem is not solved after you have followed this procedure, or if the unit fails to operate correctly upon retesting, call your service technician.

Turn to “Trouble Shooting for Operators” below for more information about troubleshooting for operators.

- Trouble Shooting for Operators** Use the checks in Table 3.2 to ensure that the power supply is configured and connected for normal operation. If you need any further troubleshooting, call your service technician.

Abbreviated References Used in Table

OVP over voltage protection
S/D shutdown

Section 3. Local Operation

User Diagnostics

Table 3.2 User Diagnostics

Symptom	Check	Further Checks and Corrections
No output and the display is blank.	In input voltage within specified range?	Connect to appropriate voltage source. See “AC Input Power Connection” on page 28.
	Power switch ON?	Turn on power.
	Internal circuit?	See your service technician.
No output but the display turns on.	OVP LED turned on?	See “Using Over Voltage Protection (OVP)” on page 38.
	Front panel S/D LED turned on?	See “Using the Shutdown Function” on page 39.
	Current limit set to zero?	See “Standard Operation” on page 35.
	Voltage control set to zero?	
	REM LED turned on?	If using remote analog control, check your analog programming source (See “Remote Operation” on page 49).
Internal circuit.	See your service technician.	
Output voltage not adjustable.	Is unit in current limit mode? (Red Current Limit mode LED turned on.)	Turn current knob clockwise to increase current limit. Reduce load if current is at maximum. See “Standard Operation” on page 35.
	Is unit in remote programming mode? (Green PGM LED is turned on.)	If using remote analog control, check your analog programming source (See “Remote Operation” on page 49). If not, refer to your digital interface manual.
	Is unit at maximum voltage or current limit?	Reduce load for lower voltage or current requirement.

Section 3. Local Operation
User Diagnostics

Symptom	Check	Further Checks and Corrections
Output voltage fluctuating or regulation poor.	Is unit at current limit?	Increase current limit setting or reduce load. See “Standard Operation” on page 35.
	Is input voltage within specified range?	Connect to appropriate AC voltage source. See “AC Input Power Connection” on page 28.
	Are sense lines connected?	See “Load Connection” on page 30, and “Remote Sensing” on page 33.
	is unit under remote analog control?	Ensure that program source is stable.
	Internal circuit.	See your service technician.
Output oscillating.	Internal circuit.	See your service technician.

Section 3. Local Operation
User Diagnostics

Section 4. Remote Operation

Introduction

The switches and connector on the rear panel of the power supply allow you to program the supply with an analog device or to readback analog signals.

Remote Digital Programming You can operate the power supply from a computer if you have the optional GPIB or RS-232 interface card installed. Refer to the separate interface manual for all setup and operation instructions for remote digital programming.

Remote Analog Programming of Output Voltage and Current Limit

Remote analog programming allows control of the power supply's output voltage and output current limit to shift from local operation at the front panel voltage and current controls to external analog input sources. As you vary the programming source, the power supply's output varies proportionally over its output range.

Using remote analog programming requires that you make connections to the J210 connector on the power supply's rear panel. See "Rear Panel J210 Connector" on page 15. To reduce radiated emissions, add a ferrite block to the wires that go to the J210 connector. The 1 inch square ferrite block with built in housing clip is packaged and shipped with the power supply.

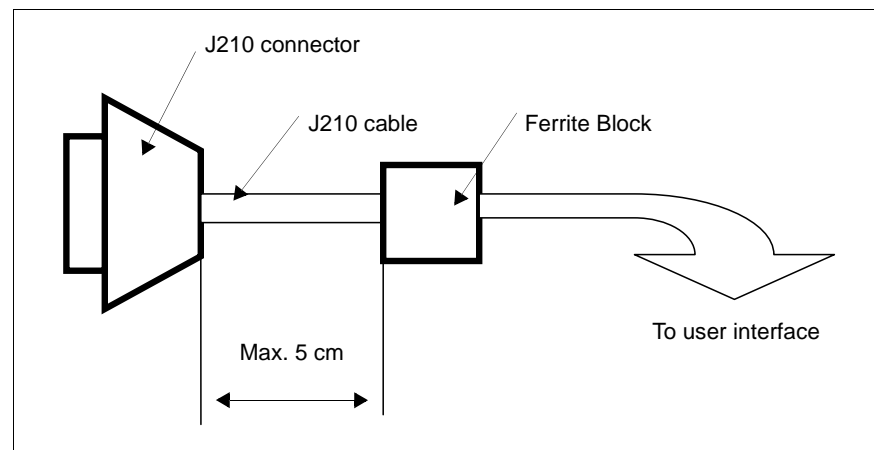

Figure 4.1 J210 User Cable with Ferrite Block

Section 4. Remote Operation

Readback and Status Indicators

Remote Programming Options See Table 4.1 for a summary of the options available to you for programming output voltage and current limit using an analog source.

Table 4.1 Remote Programming Options

Control of...	Programming Scale
Output voltage	0-10 V voltage sources
Current limit	0-10 V voltage sources

Programming Output Voltage with a 0-10 Vdc Voltage Source

1. Connect J210 pin 6 (remote voltage program select) to J210 pin 8 (auxiliary ground).
2. Connect the control voltage source between pin 14 (voltage program) and pin 13 (program return).
3. Vary the external voltage from 0-10 Vdc to cause the power supply output to vary from 0-100% of rated output voltage.

Programming Output Current with a 0-10 Vdc Voltage Source

1. Connect J210 pin 7 (remote current program select) to J210 pin 8 (auxiliary ground).
2. Connect the control voltage source between J210 pin 5 (current program, positive) and pin 8 (program return).
3. Vary the external voltage from 0-10 Vdc to cause the power supply current limit to vary from 0-100% of rated output.

Readback and Status Indicators

Voltage and Current Readback **Voltage Readback** Connect a voltage monitoring device between J210 connector pin 15 (voltage readback - positive) and pin 13 (program return - negative).

Range: 0-10 V = 0-100% full rated voltage output of power supply

Current Readback Connect a voltage monitoring device between J210 connector pin 12 (current readback - positive) and pin 13 (program return - negative).

Range: 0-10 V = 0-100% full rated current output of power supply

Status Flags

The power supply has 5 status flags to indicate the operating state. The S/D LED on the front panel, and 4 LEDs visible from the top of the unit. The flags, listed in order from front to rear, are OTP, OVP, SNS-PROT and AC-FAIL.

OTP	Over-temperature protection indicates a supply shutdown due to over-temperature triggering the OTP circuitry. The unit has an auto-restart feature when the supply's temperature is within the correct temperature range again.
OVP	Over-voltage protection indicates shutdown due to output voltage exceeding the threshold preset using the OVP trimpot on the front panel.
SNS-PROT	Sense line protection indicates a shutdown due to a voltage drop on the load lines exceeding 5 V per line (3 V per line for 7.5 V model) in remote sense mode. This condition may also occur if the unit is operated without the J207 default sense line connector.
AC-FAIL	AC fail indicates a mains V_{ac} input out of the supply's specified range (i.e. below 85 V_{ac} or over 264 V_{ac}).

In the event of one of the flags being tripped, the flag is raised along with S/D flag on the front panel. An S/D flag with none of the other 4 flags indicates remote shutdown (J210,1 and 2).

Section 4. Remote Operation

Status Flags